



1956

MIDDLE EAST TECHNICAL UNIVERSITY

DEPARTMENT OF ELECTRICAL AND ELECTRONICS ENGINEERING

Ph. D. QUALIFYING EXAMINATIONS
GUIDEBOOK

October 2000

CONTENTS

FOREWORD.....	1
PART I PROCEDURES.....	2
How to apply to take the qualifying examinations.....	2
Major and minor examinations.....	2
PART II DESCRIPTION OF THE SPECIALIZATION AREAS	4
Definitions	
Specialization Area.....	5
Core of Specialization Area.....	5
Background Subjects.....	5
Special Subjects.....	6
Major Examination.....	6
Minor Examination.....	6
Specialization Areas of the Department	
Biomedical Engineering.....	7
Circuits and Systems.....	9
Computer Engineering.....	11
Control Systems.....	13
Electrical Machines and Power Electronics.....	15
Electromagnetics, Antennas and Microwaves.....	17
Electronics.....	20
Power Systems.....	22
Robotics.....	24
Signal Processing.....	26
Telecommunications	28
PART III RULES AND REGULATIONS CONCERNING THE Ph.D. QUALIFYING EXAMINATIONS IN METU	
Doctoral Qualifying Examination (Article 28).....	30

FOREWORD

This guidebook is intended to provide information that the Ph. D. students of the Electrical and Electronics Engineering Department of METU need when they are preparing for the qualifying examinations.

The objective of the doctoral program is to motivate and prepare students such that they are able to a) carry out research independently, b) analyze scientific events with wide and deep perception and c) determine necessary steps to reach new synthesis and make contributions. Courses taken during doctoral education and the qualifying examination provide means of acquiring wide and deep knowledge in the related field, which is essential to grasp and enhance different aspects of science. Original contributions to the field are furthermore expected from the thesis work of the Ph. D. candidate.

In the following pages, the details of a Ph. D. qualifying examination procedure, which is consistent with the above objective, are given. In part I, the application procedures for the qualifying examination and the important points that the student should bear in mind, are provided. In part II, definitions of the various terms that are used in the description of the qualifying examinations are included. Also in this part, the specialization areas at the Department are identified and the contents of the topics contained in the background subjects, core subjects and special subjects are written in detail together with the related courses. This section should be studied carefully by the student before choosing the topics of the major and minor qualifying examinations and the student's supervisor's consent must be sought after consultations. The current rules and regulations affecting the qualifying examinations are included in Part III.

We hope that students will find this guidebook useful.

The Committee for the Qualifying Examinations

PART I PROCEDURES

HOW TO TAKE QUALIFYING EXAMINATIONS?

HOW TO APPLY?

- 1- Ph. D. qualifying examinations are held twice yearly, in May and in November.
- 2- A Ph. D. student must take his Ph. D. qualifying examinations in his fifth semester at the latest. Students who fail the qualifying examination are asked to take the examination again the following semester. Students failing the examination a second time are dismissed from the doctoral program.
- 3- Ph. D. Qualifying Examinations are conducted entirely in English.
- 4- Students who are going to take Ph. D. Qualifying Examinations must apply to the Department (Committee for the Ph. D. Qualifying Examinations) in April/October in written form indicating their major and minor specialization areas together with a special subject for the major examination. Their application form must be approved by their supervisors and a copy of the English proficiency examination (Language Examination for the Government Employees, KPDS, with at least 60 points out of 100; or Test of English as Foreign Language, TOEFL, with at least 173 points; or International English Language Testing System, IELTS, with at least 6.0 points from each section) certificate must be attached.
- 5- The times, dates and places of the written qualifying examinations and the names of the students whose applications are approved by the Committee for the Ph. D. Qualifying Examinations, will be announced in the beginning of May/November. The dates and times of the oral qualifying examinations which will follow the written examinations, will be declared by the coordinator of the concerned jury.

MAJOR AND MINOR EXAMINATIONS

A student is asked to take two separate examinations: 1) Major and 2) Minor Examinations.

- 1- Major Examinations are held in two parts: Written and oral. In these examinations students are responsible for the core and one of the special subjects of a specialization area.
- 2- Minor examinations are held in two parts: Written and Oral. In these examinations students are responsible for the core of a specialization area which must be different than the one chosen for major examinations.

The core and special subjects of different specialization areas together with the related courses are given in the second part of this guidebook.

As an example, a student who is going to take his major examination in "Telecommunications", will be responsible for both the core and one of the special subjects of this specialization area, and for his minor examination he will be responsible only for the core of another specialization area, for example, the core of "Computer Engineering".

PART II DESCRIPTION OF THE SPECIALIZATION AREAS

In Engineering, a "Doctorate of Philosophy (Ph.D.)" work contributes to the advancement of science and technology by developing and implementing original engineering concepts and solutions from the philosophy behind existing scientific and technological knowledge.

The Ph. D. program at the Department of Electrical and Electronics Engineering, METU, aims at conducting leading doctoral research in different areas with potential impacts abroad and nationwide. These impacts are generally in the form of copyrighted publications and/or patents together with international recognition.

It is understood that "qualifying examination" is an important milestone in the course of a Ph. D. program. In order to achieve the main goals of a Ph. D. degree, a student is expected to grasp not only the subject area he is going to specialize, but also be equipped with at least one more area of the related disciplines of the department. In this respect, a Ph. D. student is asked to take his minor examination in a different specialization area other than his own, in which he is going to take his major examination.

In what follows, a relevant and balanced Ph. D. qualifying examination procedure, for Electrical and Electronics Engineering Department Ph. D. students, is given. To establish such a procedure, the electrical and electronics engineering Ph. D. education is analyzed and the vertically integrated courses are grouped as background, specialization and special subjects. These terms are defined in the following sections and the diagram below is given to clarify the grouping of courses mentioned in this document.

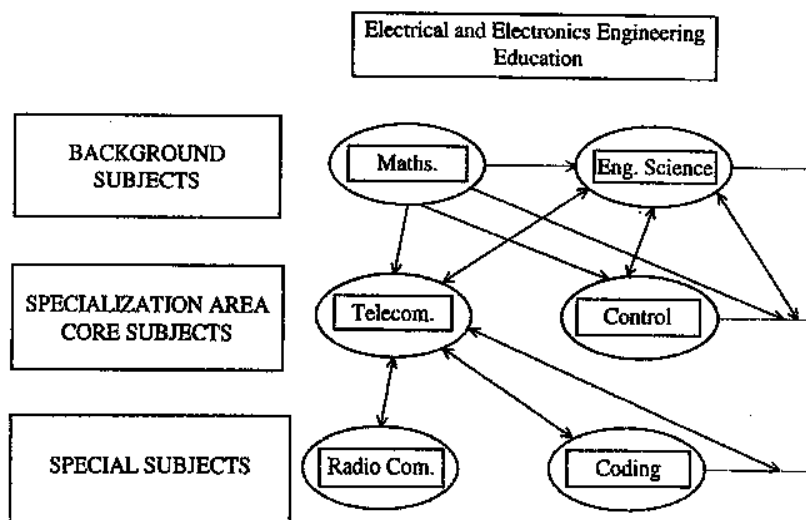

DEFINITIONS:

A- Specialization Area

This term represents a major area of research and practice and is defined by a coherent set of subjects. The specialization areas are identified according to the existing research activities of the department. (These areas will be updated in the future when necessary).

Main specialization areas in the Department of Electrical and Electronics Engineering, METU, at present, are identified as follows:

- 1) Biomedical Engineering
- 2) Circuits and Systems
- 3) Computer Engineering
- 4) Control Systems
- 5) Electrical Machines and Power Electronics
- 6) Electromagnetics, Antennas and Microwaves
- 7) Electronics
- 8) Power Systems
- 9) Robotics
- 10) Signal Processing
- 11) Telecommunications

B- Core of a Specialization Area

Core defines the fundamentals and essence of a specialization area and is composed of subjects essential to do or follow research in all branches of that specialization area.

The core must contain at least two graduate courses.

C- Background Subjects

These are the subjects that form the basic knowledge for studying in a specialization area.

Background subjects are composed of

a) Undergraduate courses compulsory for all students of Electrical and Electronics Engineering.

b) Courses that do not belong to a specialization area but are nevertheless necessary to help in order to follow and understand fully the concepts in that particular area. These courses typically contain material common to several specialization areas.

D- Special Subjects

Special subjects are those areas of study which are specific or closely related to a specialization area having in depth coverage of the relevant subject.

E- Major Examination

This examination aims at evaluating the student's knowledge and analysis skills in the core subjects and in one of the special subjects suited to the intended research topic of the student.

The area of coverage is chosen so that the student has an in depth understanding of the field and also has the opportunity to do and follow research in overlapping branches of the specialization area. The coverage is limited to a manageable number of courses.

F- Minor Examination

This examination aims at evaluating the student's knowledge and limited analysis and synthesis skills in the core of a specialization area.

GENERAL

A Ph. D. student must take a major examination in a specialization area and a minor examination in the core of another specialization area. Each examination consists of separate written and oral sessions.

In the following pages background subjects, core subjects and special subjects of the presently existing specialization areas are described.

BIOMEDICAL ENGINEERING

Ph. D. QUALIFYING EXAMINATIONS

Background Subjects:

- **Signal processing:** Discrete-time signals and systems, sampling and reconstruction, linear time invariant systems, fast Fourier transform methods, Fourier analysis of signals using discrete Fourier transform, optimal filtering and linear prediction.
- **Linear System Theory:** Linear spaces, linear transformations, matrix algebra, differential equations. System concept: Dynamical system representation. Linear system time varying and time invariant representation.

Related courses: EE 430, EE 501

Core Subjects:

- **Modeling and instrumentation for physiological systems:** Electrical Sources and Fields, Introduction to Membrane Biophysics, Action Potentials, Volume Conductor Fields, Electrophysiology of the Heart, Electrocardiography (ECG), electric and magnetic lead fields, Electroencephalography (EEG), Magnetoencephalography (MEG), Electroneurogram (ENG), Electromyogram (EMG), Biopotential electrodes, Biopotential amplifiers, Patient safety, Grounding, Isolation, Shielding, Simple mechanical model of the cardiovascular system (CVS), Measurement of pressure and blood flow, The simple mechanical model of the ventilation, Measurement of respiratory volumes and flow, Models of O₂ and CO₂ transport in the respiratory and cardiovascular system, Models of neural regulation of respiratory system and CVS, Therapeutic and prosthetic devices.
- **Medical imaging:** Image reconstruction with nondiffracting sources in two dimensions, Image reconstruction with nondiffracting sources in three dimensions, Algebraic reconstruction algorithms, Ultrasonic Computed Tomography, Tomographic Imaging with Diffracting Sources, Ultrasonic Reflection Tomography, MRI methods, Flow and Flow-related MRI, Nuclear Tomographic Imaging, New Imaging Modalities.

Related Courses: EE 416, EE 519, EE 515

Special Subjects:

- **Digital Image Processing:** Two-dimensional (2D) signals; discrete Fourier analysis of 2-D signals, 2-D Z-transform and recursive systems, design and implementation of 2-D filters, image enhancement, image coding.

Related Courses: EE 634

- **Physiological Control Systems:** Definition of and examples of homeostasis, body fluid compartments and compartmental analysis, models of the cardiovascular and respiratory systems, hormonal control mechanisms, neural control mechanisms, regulation of body fluid volumes and electrolytes, mathematical modeling, simulation and identification of physiological systems-, associated numerical methods.

Related Courses: EE 518

- **Numerical techniques in Electromagnetics:** Numerical solution of matrix equations and matrix eigenvalue problems, method of moments, finite difference and finite element methods, variational methods, spectral domain approach, the use of these methods in the solution of various antenna and scattering problems, and in the analysis of passive microwave component

Related Courses: EE 522

CIRCUITS AND SYSTEMS

Ph. D. QUALIFYING EXAMINATIONS

Background Subjects:

- **Basic Circuit Theory:** Lumped elements and circuits, resistive circuits, operational amplifiers, dynamic circuits, sinusoidal steady state analysis, complex frequency domain analysis, frequency response.
- **Basic System Theory:** Linear spaces and linear transformations, dynamical system representations, linearity, time-invariance, impulse response, system function, stability.
- **Basic Signal Theory:** Signal classification, convolution, correlation, Fourier series and transform, Laplace and z-transformations, sampling and reconstruction, random signals, stationarity, ergodicity, power spectral density, transmission of random signals through linear systems, introductory stochastic processes.

Related Courses: EE 306/EE 531, EE 430, EE 501, EE 502.

Core Subjects:

- **Circuit Theory:** Lumped elements and circuits, circuit topology, general circuit analysis, circuit theorems, passivity and stability. Characterizations of one-port and multiport RLCM circuits (positive real rational, bounded real rational and Foster functions and matrices), synthesis of one-port and two-port LC, RC and RL circuits, synthesis of one-port RLCM circuits.
- **Functional Analysis and Operator Theory:** Metric spaces, normed spaces, Banach spaces, inner product spaces, Hilbert spaces. Separability and completeness. Banach fixed point theorem, approximation theory, linear operators on normed spaces.
- **Passive, Active and Digital Filters:** Approximation methods, lossless filters (synthesis of lossless two-ports between resistive terminations, frequency transformations), phase and loss equalizers, active RC filters, infinite impulse response and finite impulse response digital filters, finite precision numerical effects, switched capacitor filters.

Related Courses: EE 507, EE 508, EE 601.

Special Subjects:

- **High Frequency Filters and Matching Circuits:** Distributed circuits, distributed element filter design, design of singly and doubly terminated lossless matching circuits.

Related Course: EE 509

- **Multiresolution Signal Analysis:** Fundamentals of signal decompositions, filter banks, wavelets, algorithms and complexity, subband coding.

Related Course: EE 505

COMPUTER ENGINEERING Ph. D. QUALIFYING EXAMINATIONS

Background Subjects:

- **Logic Design:** Number systems. Boolean algebra. Simplification of Boolean functions. Combinational logic. Synchronous and asynchronous sequential logic.
- **Data Structures:** Arrays. Stacks. Queues. Link Lists. Trees. Hash tables. Graphs. Searching and sorting algorithms.
- **Principles of Computer Architecture:** CPU organization. Arithmetic logic unit

Related Courses: EE 441, EE 445.

Core Subjects:

- **Operating Systems:** Concurrent processes. Process scheduling. Memory management. Virtual memory. Deadlocks. Distributed systems. File systems. Shell programming.
- **Computer Networks:** ISO-OSI models. The medium access sublayer. ALOHA and LAN protocols. IEEE 802.2 and ethernet. Data link layer. Error detection and correction. Data link protocols. The network layer. Routing. Congestion control. Internet working. The transport layer. Internet and Internet tools.
- **Computer Architecture:** Microprogramming. Bit slicing. Arithmetic processor design. Arithmetic algorithms. Memory organization. Parallel processing. Multiprocessor systems. Peripheral organization. I/O processing. I/O controllers.
- **Microprocessor:** Microprocessor architecture. microprocessor programming. Peripheral organization. Memory unit. I/O interfacing. Interrupt processed I/O. Direct memory access. Microprocessor based communication.
- **Switching and Automata Theory:** Sequential machine theory. Hartmanis- Stearns algebraic theory of sequential machines. Regular expressions. Decomposition theory. Linear sequential machines. Probabilistic automata. Fault detection experiments. Information lossless machines. Codes. Unique decodability. Formal languages. Context-free and context-sensitive languages. Turing machines. Computability. Decidability. Unsolvability.

Related Courses: EE 442, EE 444, EE 445, EE 446, EE 447, EE 545, EE 546.

Special Subjects:

- **Computer Networks:** The layered architecture. Local area networks. Data link protocols. Error correction with FEC and ARQ. Routing. Flow control. Transport protocols. Application layer protocols. Network performance. Queueing systems.

Related Course: EE 542.

- **Neural Networks:** Computer models of neuron. Supervised and unsupervised learning. Hopfield nets. Perceptrons. Backpropagation learning algorithms. Self organization and memories. Neurocomputing for pattern recognition. Expert systems. Optimization problems.

Related Course: EE 543.

- **Digital Applications:** Multiprocessors. Interconnection schemes. Cache coherence. Pipelined processors. Coprocessors. Transputers. Microcontrollers. Digital control of processes.

Related Course: EE 548.

- **Artificial Intelligence:** LISP programming. Description matching. Goal reduction. Natural constraints. Solution paths. Games. Logic. Theorem proving. Knowledge representation. Natural language understanding.

Related Course: EE 586.

CONTROL SYSTEMS

Ph. D. QUALIFYING EXAMINATIONS

Background Subjects:

- **Linear System Theory:** Linear spaces, linear transformations, matrix algebra, differential equations. System concept; Dynamical system representation. Linear system time varying and time invariant representation.
- **Optimization:** Unconstrained nonlinear optimization: Steepest descent, Newton, conjugate gradient and Quasi-Newton type of algorithms. Constrained optimization algorithms. Fundamental theorems of linear optimization and the simplex algorithm.

Related Courses: EE 501, EE 553.

Core Subjects:

- **Linear System Analysis:** Dynamical system representations with emphasis to evaluation of system behavior: duality, controllability, observability and their relevant transform techniques.
- **Nonlinear Control Systems:** State space analysis methods: state trajectories and singularity analyses; analytic techniques of periodic phenomena: perturbation methods; equivalent linearization and oscillations in nonlinear feedback systems; stability and predictability of nonlinear systems.
- **Feedback Systems:** design of dynamic compensators; harmonic realization methods and oscillation control in linear and nonlinear feedback systems.
- **Discrete Time Control Systems:** time domain analysis; sampled data systems; stability; observer design; state space design methods, quantization effects.

Related Courses: EE 302, EE 402, EE 404/EE 555, EE 502

Special Subjects:

- **Intelligent Control:** Methodologies: Learning Control, Fuzzy Control, Neuro Control, Nonparametric Models of Uncertainty.

Related Course: EE 559.

- **Optimal Control:** Calculus of variations, optimality; Linear Quadratic Optimal Control Problems; Computational approaches.

Related Course: EE 554.

- **Robotics:** Introduction to Robotics: mathematics of manipulators including restructured and multiarms, inverse kinematics, dynamics, task and path planning. Robot hand gross motion control. Obstacle Avoidance. Hand fine motion control: contact analysis.

Related Course: EE 588.

- **Predictive Control:** Nonlinear Dynamics. Maps, flows and local geometric theory of dynamics. Point attractors. Multiple nested cyclic attractors. Basins of attraction. Julia Sets. Fourier Spectrum.

Related Course: EE 655.

- **Process Control:** Mathematical modeling of fundamental distributed parameter processes. Lumped parameter approximation. Disturbance filtering characteristic of control loops. Fundamental of control of basic processes. Identification, measurement and Instrumentation for the control of industrial processes.

Related Courses: EE 407, EE 408.

- **Adaptive Control:** Gauss- Markov process and stochastic differential equations. Bayesian estimation theory. Properties of estimators. State estimation for linear filters. Smoothing and prediction. Nonlinear estimation. Filter implementations. System identification and adaptive control system models. Volterra and Wiener Characterizations for nonlinear systems. On-line parameter identifications. Stochastic approximation search and filtering methods. Various adaptive control strategies. Stability considerations.

Related Courses: EE 557, EE 558.

Additional Background: Stochastic processes

ELECTRICAL MACHINES AND POWER ELECTRONICS

Ph. D. QUALIFYING EXAMINATIONS

Background Subjects:

- **Linear System Theory:** Linear spaces, linear transformations, matrix algebra, differential equations. System concept: Dynamical system representation. Linear system time varying and time invariant representation.
- **Electromechanical Energy Conversion:** Magnetic circuits, stored energy, losses, principles of electromechanical energy conversion. Singly and multiply fed electromechanical systems, DC machines. Rotating fields, induction and synchronous machines.

Related Courses: EE 501, EE 553, EE 361, EE 362

Core Subjects:

- **Electromechanical Energy Conversion and Electrical Drives:** Sizing of electromechanical energy conversion devices, the relationship between losses and size. Performance calculation of electrical machines. Dynamic behavior of electrical machines. DC and AC motor speed control systems and their performance.
- **Power Electronics:** Power switches, protection of power semiconductors, thermal behavior, natural commutation, rectifiers, harmonics, power factor and utility factor for distorted waveforms. Forced commutation, inverters, inverter voltage control, choppers, parallel and series operation of static converters.
- **Generalized Machine Theory:** Matrix equations of electrical machines. Active and passive transformations in electrical machines and circuits. Analysis of transient, steadystate, balanced and unbalanced operation of electrical machines. Behavior of machines around an operating point, simplified models, applications.

Related Courses: EE 463, EE 464, EE 462, EE 563, EE 561

Special Subjects:

- **Electrical Machine Design:** Design of DC and AC machines and transformers to specification. Calculation of electrical machine parameters from magnetic circuit. Torque harmonics. Computation of performance at the design stage.

Related Course: EE 564

- **Special Electrical Machines:** Stepping and switched reluctance motors and their characteristics. Drive circuits for such motors. Calculation of drive-system characteristics at variable speed operating conditions; acceleration, deceleration and control techniques.

Related Course: EE 568

- **Advanced Power Electronics:** Design of forced commutation circuits for inverters and choppers. Switch mode power supplies, buck-boost circuits, unity power factor rectifiers, advanced inverter modulation techniques, inverters as reactive power generators and for harmonic elimination, resonant inverters, resonant DC link inverters, resonant AC link inverters. Cycloconverters, matrix converters.

Related Course: EE 569.

ELECTROMAGNETICS, ANTENNAS AND MICROWAVES

Ph. D. QUALIFYING EXAMINATIONS

Background Subjects:

- **Telecommunications:** Analog transmission, modulation techniques, superheterodyne receivers, frequency division multiplexing, sampling process, digital transmission, noise.
- **Signal Processing:** Discrete-time signals and systems, sampling and reconstruction, linear time invariant systems, fast Fourier transform methods, Fourier analysis of signals using discrete Fourier transform, optimal filtering and linear prediction.
- **Linear Algebra:** Linear spaces, linear transformations, Hilbert spaces.
- **Mathematics:** Complex calculus, special functions, partial differential equations.

Related Courses: EE 435, EE 436, EE 430, EE 501, PHYS 503.

Core Subjects:

- **Electromagnetic Theory:** Fundamental concepts and theorems. Plane wave functions, cylindrical wave functions, spherical wave functions, wave transformations.
- **Antennas and Propagation:** Antenna parameters, linear antennas, antenna arrays, radiation from slot and aperture antennas, elements of ground wave, tropospheric and ionospheric propagation.
- **Microwaves:** Transmission lines, field and distributed circuit analysis, propagation in waveguiding structures, impedance transformation and broadband matching techniques. Matrix representation of microwave networks, generalized scattering parameters, active and nonlinear microwave systems, microwave equivalent circuits.
- **Numerical Methods:** Numerical solution of matrix equations and matrix eigenvalue problems, method of moments, finite difference and finite elements methods, variational methods, spectral domain approach.

Related Courses: EE 425, EE 427, EE 522, EE 523, EE 527.

Special Subjects:

- **Microwaves:** Microwave theory, applications and basic concepts of antenna theory: Scattering parameters, passive reciprocal and nonreciprocal devices, hybrids,

electromagnetic resonators, basic microwave filters and periodic structures. Synthesis of lumped and distributed element filters, equivalent circuits and circuit transformations for realization, filter design using prototypes. Field equivalence principles, surface wave antennas, microstrip antennas and arrays, broadband antennas, reflector antennas, horns.

Related Courses: EE 428, EE 509, EE 525, EE 528

- **Antennas and Propagation:** Wave propagation fundamentals, ground wave, tropospheric and ionospheric propagation, Antenna and environmental noise. Field equivalence principles, surface-wave and microstrip antennas, arrays, broadband antennas, reflector antennas, horn antennas. Induced current and aperture integration formulations, the Huygens-Fresnel principle, geometrical optics, plane wave spectrum representation, fast analysis of aperture type antennas, fast and slow wave structures, array analysis and synthesis techniques.

Related Courses: EE 524, EE 525, EE 526.

Additional Background: Optimization: Optimization algorithms such as steepest descent, Newton and Quasi-Newton, fundamental theorems of linear optimization and the simplex algorithm.

Related Course: EE 553.

- **Radar Engineering:** Wave propagation fundamentals, ground wave, tropospheric and ionospheric propagation, Antenna and environmental noise. Induced current and aperture integration formulations, the Huygens-Fresnel principle, geometrical optics, plane wave spectrum representation, fast analysis of aperture type antennas, fast and slow wave structures, array analysis and synthesis techniques. Design principles and performance evaluation of pulsed radars, Statistical detection theory and radar cross-section of targets, CW, FM and Doppler radars. SAR and ISAR radars. Radar receiver design, high power microwave generation and amplification.

Related Courses: EE 524, EE 526, EE 625, EE 626.

Additional Background: Optimization: Optimization algorithms such as steepest descent, Newton and Quasi-Newton, fundamental theorems of linear optimization and the simplex algorithm.

Related Course: EE 553.

- **Electromagnetic Field Theory:** Green's functions in rectangular, cylindrical and spherical coordinates, relation with the solution of EM related inhomogeneous partial differential equations, Watson transformation, the T-Matrix method, vector wave functions, dyadic Green's functions. Asymptotic series, asymptotic evaluation of integrals, Kirchoff and physical optics approximations, Luneberg-Kleiner expansion, the eikonal and transport equations, geometrical optics, geometrical theory of diffraction, physical theory of diffraction, applications.

Related Courses: EE 521, EE 624

- **Optics:** Ray optics, wave optics, beam optics, Fourier optics and photon optics electromagnetic theory of optics and polarization, optical waveguides, fiber optics, optical resonators, optical fiber sensors, optic systems. Application of Fourier theory to the analysis and synthesis of optical imaging and optical data processing systems. Propagation and diffraction of light. Fresnel and Fraunhofer approximations, image formation with coherent and incoherent light, optical data processing and holography.

Related Courses: EE 627, EE 635.

Additional Background: Optical propagation in fibers, cables, connectors and couplers, principles of optical communication systems. Coherent and non-coherent optical fiber communication systems. Principles of lasers, quantum electronics, laser plasmas, laser optics, laser systems and applications. Optimization algorithms such as steepest descent, Newton and Quasi-Newton, fundamental theorems of linear optimization and the simplex algorithm.

Related Courses: EE 438/EE 512, EE 553, EE 614.

ELECTRONICS

Ph. D. QUALIFYING EXAMINATIONS

Background Subjects:

General Electronics background including non-linear electronics.

- **Solid-State Electronics:** Basic semiconductor concepts, physics of p-n junction diodes, bipolar junction transistors, field effect transistors, biasing and small-signal models, secondary affects, and dynamic models.
- **Analog Electronics:** Amplifiers and frequency response, feedback in amplifiers, differential pair stages, current mirrors, operational amplifiers, and power amplifiers.
- **Digital Electronics:** Large signal transistor models, TTL, ECL, MOS, CMOS logic gates, and regenerative circuits.
- **Nonlinear Electronics:** amplitude modulation and analog multiplication, coupling networks, sinusoidal oscillators, frequency mixers, and converters.

Related Course: EE 412

Core Subjects:

- **Digital VLSI Design:** Design techniques for rapid implementations of very large-scale integrated (VLSI) circuits, MOS technology and logic, and design for testability.
- **Analog VLSI Design:** NMOS and CMOS processes, transistor circuit modeling, current mirrors, operational amplifiers, pseudo analog techniques, continuous time and switched capacitor filters, A/D and D/A conversion, oscillator and phase locked loop design.
- **Semiconductor Device Modeling:** Elements of Quantum mechanics, energy band theory, semiconductor fundamentals, carrier transport models, semiconductor device modeling, Monte Carlo technique for device simulation.

Related Courses: EE 413, EE 617, EE 513

Special Subjects:

- **Solid-State Devices:** III-V compound semiconductor technology. Physics, fabrication, modeling, and integrated circuit applications of III-V compound semiconductor electron devices (MESFETs, MODFETs, and HBTs). Novel heterostructure electron devices. Optoelectronic integrated circuits

Related Course: EE 619

Additional background: Microwave Engineering: Properties of scattering parameters, generalized scattering parameters, Microwave transistor amplifier design-, gain stability, noise. Microwave transistor oscillator and mixer design, simplified signal flow graph analysis, coupled lines, directional coupler, Schiffman's differential phase shifter. Hybrids and power dividers. Richards' frequency: transformation, Richards' theorem. Kuroda's identities.

Related Course: EE 527

- **Integrated Microsensors:** Fundamental principles and operation of integrated solidstate sensors. Micro-Electro-Mechanical Systems (MEMS) technologies. Microsensor technology including silicon micromachining and wafer bonding. Microstructures for measurement of visible and infrared radiation, pressure, acceleration, and temperature. Sensor interface circuits. Microactuators.

Related Course: EE 610

Additional background: Microfabrication processes, characterization and testing methods in semiconductor technology.

Related Courses: Physics 411 or Physics 412 or Physics 527

- **Integrated Circuits Design:** MOS and CMOS circuits and processing technology, circuit characterization and performance estimation. CMOS circuit and logic design, structured design and testing. IC Design methodologies.

Related Course: EE 618

- **Beam Electronics:** Lens theory, electron motion, electronic space charge, analytical determination of electrostatic fields, general properties of electrostatic lenses, magnetic electron lenses, electron guns, design considerations for selected beam systems.

Related Course: EE 613

Additional Background: Electromagnetic Wave Theory: Fundamental concepts and theorems, plane, cylindrical and spherical wave functions.

Related Course: EE 523

- **Optoelectronics:** Propagation of rays, spherical waves and Gaussian beams, optical resonators, modulation and detection of optical radiation, noise in optical detection and generation, interaction of light and sound. Lasers, fiber optics, and their applications.

Related Course: EE 615

Additional Background: Lasers: Laser plasma, laser optics, principal lasers, laser systems and applications, and safety problems.

Related Course: EE 614

POWER SYSTEMS

Ph. D. QUALIFYING EXAMINATIONS

Background Subjects:

- **Computational Methods:** Numerical errors and their estimation, Approximation and interpolation, solutions of linear and nonlinear simultaneous equations, numerical differentiation and integration, introduction to statistical methods.
- **Optimization:** Unconstrained nonlinear optimization: Steepest descent, Newton, conjugate gradient and Quasi-Newton type of algorithms. Constrained optimization algorithms. Fundamental theorems of linear optimization and the simplex algorithm.
- **Linear System Theory:** Linear spaces, linear transformations, matrix algebra, differential equations. System concept: Dynamical system representation. Linear system time varying and time invariant representation.

Related Courses: EE 443, EE 553, EE 501.

Core Subjects:

- **Power System Analysis:** Structure of electrical power systems, Electrical characteristics of transmission lines, transformers and generators, representation of power system, symmetrical and unsymmetrical faults. Matrix analysis and solutions of power systems, load flow and short circuit analysis, transient stability analysis.
- **Wave Propagation:** Wave equations, Modeling of aerial lines and cables, modal analysis of transmission lines, power line carrier communications, solution of transmission line transients using lattice, Fourier transform and time domain methods.
- **Economic Operation of Power Systems:** Modern power system operation, economic dispatch, transmission losses, linear and nonlinear programming techniques, hydrothermal coordination, power system security and rescheduling.

Related Courses: EE 471, EE 472, EE 571, EE 579.

Special Subjects:

- **High Voltage:** Field analysis, electrical breakdown in gases, breakdown in non-uniform field and corona, electrical breakdown of liquids and solids, erosion, insulating materials. Generation and measurement of high AC, DC, and impulse currents, testing transformers and series resonant circuits, sphere and uniform field gaps, dielectric measurements. Principles of insulation coordination, lightning

performance. Insulation principles in high voltage equipment, lightning discharges and over voltages, corona effects, electromagnetic interference generated by high voltage systems, insulators, circuit breakers, high voltage transformers and cables. High voltage measurement techniques, high voltage components, impulse current measurements, dielectric measurements, partial discharges.

Related Courses: EE 475, EE 476, EE 572, EE 575, EE 576.

- **Distribution and System Protection:** Fundamentals of distribution systems, forecasting methods, primary and secondary distribution, operational characteristics of cables, aerial lines and transformers, overcurrent and thermal protection, economics of distribution systems. Overcurrent protection, differential protection, motor protection. Distance protection, high speed protection, integrated protection.

Related Courses: EE 474, EE 478, EE 577.

- **Operation and Planning:** Power system planning concepts, generation system and transmission planning. Real time monitoring, principles of computer control systems, contingency and configuration analysis, detection, identification and correction of errors, real-time observability analysis. Modern power system operation and control techniques, unit commitment, interchange of power and energy, dynamic modeling of power systems, regulation, economic dispatch. Computational techniques, power system modeling, large sparse linear systems, vector and parallel processing.

Related Courses: EE 578, EE 574, EE 671, EE 674.

- **Power System Stability and Control:** Power system transient and dynamic stability, multimachine transient stability, speed governors and stabilizers. Modern power system operation and control techniques, dynamic modeling of power systems, regulation, economic dispatch. Computational techniques, power system modeling, large linear systems, vector and parallel processing.

Related Courses: EE 563, EE 573, EE 671, EE 674.

ROBOTICS

Ph. D. QUALIFYING EXAMINATIONS

Background Subjects:

- **Linear System Theory:** Linear spaces, linear transformations, matrix algebra, differential equations. System concept: Dynamical system representation. Linear time-varying and time-invariant representations.
- **Signal Processing:** Discrete-time signals and systems. Sampling and reconstruction. Linear time invariant systems. Fast Fourier transform methods. Fourier analysis of signals using Discrete Fourier Transform. Optimal filtering and linear prediction.
- **Microprocessors:** Microprocessor architecture. Microprocessor programming. Peripheral organizations. Memory unit. I/O interfacing. Interrupt processed I/O. Direct memory access. Microprocessor based communication.

Related courses: EE 430, EE 447, EE 501.

Core Subjects:

- **Kinematics and Dynamics:** Direct kinematics. Inverse kinematics. Differential motion and statics. Manipulator, link and tool Jacobian matrices. Joint space singularities. Resolved-motion-rate control. End-of-arm compliance and stiffness. Lagrange's equation. Newton-Euler formulation.
- **Robot Control:** Single-joint linear controllers, stability analysis through Lyapunov's. Gravity control. Computed torque control. Impedance control.
- **Robot Vision:** Edge detection. Shape analysis. Invariant moments. Thresholding. Region labeling. Region growing. Image smoothing. Perspective transformations. Structured illumination. Camera calibration.

Related courses: EE 587, EE 642, EE 701.

Special Subjects:

- **Machine Intelligence:** Supervised and unsupervised learning. Backpropagation learning algorithms. Self-organization, neurocomputing. Expert systems. Uncertainty measures, learning control, neuro control, fuzzy control. Petri nets, learning control, reinforcement learning. Lisp programming, description matching, goal reduction, natural constraint, solution paths, games, logic, theorem proving, knowledge representation, natural language understanding.

Related courses: EE 543, EE 559, EE 586.

- **Robot Hands and Manipulation:** Grasp Jacobian and its use in grasp planning, contact analysis, compliant motion, collision-free wrist path planning, force closure/form closure, linear and nonlinear complementarity problems.

Related course: EE 588.

- **Machine Perception:** Bayes decision theory, parameter estimation and supervised learning, nonparametric techniques, linear discriminant functions, unsupervised learning and clustering, scene analysis, Lisp programming, description matching, goal reduction, natural constraints, solution paths, games, logic, theorem proving, knowledge representation, natural language understanding.

Related courses: EE 583/CENG 564, EE 586.

SIGNAL PROCESSING

Ph. D. QUALIFYING EXAMINATIONS

Background Subjects:

- **Introductory DSP:** Discrete-time signals and systems. Discrete Fourier Transform. Sampling and reconstruction. Linear time invariant systems. Structures for discrete time systems. Filter Design techniques. Fast Fourier Transform.
- **Stochastic Processes:** Characterization. Correlation functions. Stationarity, ergodicity. Power spectral density. Transmission of random signals through linear systems. Special processes: Gaussian, Poisson etc. Noise in electrical systems: Thermal and shot noise processes. Noise figure.
- **Linear System Theory:** Linear spaces, linear transformations, matrix algebra, differential equations. System concept: Dynamical system representation. Linear system time varying and time invariant representation.
- **Optimization:** Convexity and convex functions. Unconstrained minimization problems. Steepest descent algorithm etc. Newton and quasi-Newton methods. Constrained minimization problems and Kuhn-Tucker theory. Fundamental theorems of linear optimization and the Simplex algorithm.

Related courses: EE 430, EE 306/EE 531, EE 501, EE 553.

Core Subjects:

- **Discrete-time Random Signal Processing:** Discrete-time random signals, Linear transformations, Estimation and detection, Homomorphic processing, Optimal linear filtering, Linear Prediction.
- **Spectral Estimation:** Spectral estimation by linear prediction, MA, AR, ARMA modeling, EM method, MUSIC, ESPRIT algorithms.
- **Adaptive Signal Processing:** Wiener Filters. LMS algorithm. RLS, QR-RLS algorithms. Order recursive algorithms. Computational complexity. Filter structures and algorithms for real-time processing. IIR adaptive filtering. Applications.

Related courses: EE 503, EE 504, EE 603.

Special Subjects:

- **Image Processing:** Image representation. Image transforms. Image enhancement. Image restoration. Computer vision. Image compression.

Related course: EE 634.

- **Neural Networks:** Computer models of a neuron. Supervised and unsupervised learning. Hopfield nets. Perceptrons. Backpropagation learning algorithms. Self organization and memories. Neurocomputing for pattern recognition, expert systems, and optimization problems. Analogy between neurocomputers and computation in cerebral cortex. Characteristic differences between digital and neurocomputers.

Related course: EE 543.

- **Pattern Recognition:** Machine perception. Parameter estimation and supervised learning; nonparametric techniques. Linear discriminant functions. Unsupervised learning and clustering. Scene analysis.

Related course: EE 583.

- **Speech Processing:** Digital models for the speech signal. Time domain models for speech processing. Digital representations of speech waveform. Short time Fourier analysis of speech. Sub-band coding. Transform coding. Linear predictive coding of speech. Homomorphic speech processing. Delayed decision coding. Performance measurement in digital speech processing. Introductory speech recognition.

Related course: EE 633.

Major Exam:

Core, one of the special subjects, and the following:

Multiresolution Signal Processing: Multirate processing, Filter banks, Time and Frequency analysis: DCT, wavelets etc.

Related course: EE 505.

Minor Exam:

Core subjects.

TELECOMMUNICATIONS

Ph. D. QUALIFYING EXAMINATIONS

Background Subjects:

- **Stochastic Processes:** Characterization. Correlation functions. Stationarity, ergodicity. Power spectral density. Transmission of random signals through linear systems. Special processes: Gaussian, Poisson etc. Noise in electrical systems: Thermal and shot noise processes. Noise figure.
- **Linear System Theory:** Linear spaces, linear transformations, matrix algebra, differential equations. System concept: Dynamical system representation. Linear system time varying and time invariant representation.
- **Signal Processing:** Sampling and reconstruction. z-transform. Linear time invariant systems. Structures for discrete time systems. Filter design techniques. DFT and FFT. Fourier analysis of signals using DFT.

Related Courses: EE 306/EE 531, EE 430, EE 501.

Core Subjects:

- **Analog Transmission:** Amplitude and angle modulation methods (AM, DSCB, SSB, VSB, QAM, FM, PM). Basic systems: FDM, superheterodyning, Phase-locked loops, modulators and demodulators. Noise analysis of analog receivers.
- **Source Digitization:** Sampling theory. Quantizers. PCM, DPCM, DM etc.
- **Digital Transmission:** TDM. Line codes. Baseband pulse transmission. Passband transmission. Modulation of digital signals: ASK, PSK, FSK, MSK, QAM, Orthogonal signaling etc. Constellation diagrams. PSD of digital signals. Error performance analysis. Equalizers. Adaptive equalizers: LMS, RLS (Kalman) equalizers. Optimal sequence detection: Viterbi algorithm. Synchronization.
- **Detection, Estimation and Modulation Theory:** Bayes and Neyman-Pearson tests. Binary and M-ary hypothesis testing. Estimation theory: MS, MAP, ML estimates. Karhunen-Loeve expansion. Detection and estimation of signal parameters in white and colored noise. Estimation of continuous waveforms. Wiener-Hopf filters.
- **Basic Information and Coding Theory:** Concepts of mutual information and entropy. Channel capacity. Source and channel coding theorems. Block and convolutional codes.

Related Courses: EE 435, EE 436, EE 535, EE 536, EE 533.

Special Subjects:

- **Digital Radio Communication:** Characterization of fading multipath channels. Digital signaling over fading multipath channels. Diversity techniques. Coded waveforms for fading channels. Direct sequence spread spectrum signals. Frequency hopping spread spectrum signals.

Related course: EE 637.

Additional Background: Electromagnetic Wave propagation: Wave propagation fundamentals. Ground wave propagation. Spherical earth problem. Tropospheric propagation. Iono-spheric propagation. Environmental noise.

Related course: EE 524.

- **Coding Theory:** Arithmetic of Galois fields. Linear block codes: Cyclic codes, BCH, RS etc. Convolutional codes. Efficient decoding algorithms for block and convolutional codes. Concatenation and interleaving of codes.

Related course: EE 534.

- **Telecommunication Networks:** Digital switching. Network synchronization, control and management. Fiber optic communication systems. Concepts of ISDN. ATM networks. Traffic analysis.

Related course: EE 538.

Additional Background: Computer networks: ISO-OSI layered model. Medium access, data-link, network and transport layer protocols. Internet and internet tools.

Related course: EE 444/EE 542.

- **Communication Electronics:** Nonlinear controlled sources. Low level amplitude modulation and analog multiplication. Transformer-like networks. Nonlinear loading of tuned circuits. Tuned large scale amplifiers and frequency multipliers. Sinusoidal oscillators. Frequency mixers and converters. Small and large signal BF amplifier design. Noise considerations in RF amplifiers. Microstrip and strip line amplifiers.

Related course: EE 412/EE 511.

Additional Background: Microwaves: TEM mode transmission lines. Field and distributed circuit analysis. Waveguiding structures. Rectangular and circular wave guides. Impedance transformation and matching techniques. Scattering matrix of microwave junctions. Passive reciprocal and nonreciprocal devices. Electromagnetic resonators. Periodic structures and microwave filters. Microstripline structures and coupled lines. Solid state microwave devices.

Related courses: EE 427, EE 428.

PART III RULES AND REGULATION CONCERNING THE Ph. D. QUALIFYING EXAMINATIONS IN METU

(Published in the Official Newspaper on 25th August, 1996, No: 22738)

Doctoral Qualifying Examinations

Article 28.

- a. The names of the doctoral students who applied to take the Ph. D. qualifying examinations, are submitted to the concerned Graduate School by the Department. In order to take the doctoral qualifying examination, students must have obtained at least 60 points out of 100 in KPDS (Language Examination for government employees). Students who had KPDS in place of English proficiency examination during admission, are waived from this requirement. Doctoral students are requested to take the Ph. D. qualifying examination in their fifth semester at the latest.
- b. Doctoral qualifying examinations are held twice yearly, in May and in November.
- c. Qualifying examinations are organized and implemented by the "Committee for the Qualifying Examinations" which is composed of five members recommended by the Department Chairperson and approved by the Administrative Committee of the Graduate School for a period of three years. The Committee appoints examination juries consisting of three or five members one of which is the thesis supervisor of the Ph. D. student, for the purpose of preparing, implementing and evaluating examinations in various fields. Jury members are required to have Ph. D. degrees.
- ç. Ph. D. qualifying examination consists of written and oral examinations which grade the student's skill in the concerned scientific field and his potency towards research. Ph. D. qualifying examinations are conducted entirely in English.
- d. The committee for the qualifying examinations, upon evaluating the results of both written and oral examinations altogether, decides on a majority vote, whether the student passes or fails. This decision is submitted to the concerned graduate school by the chairperson, in written form, within three days at most.
- e. Students who fail the qualifying examination are asked to take the examination again the following semester. Students failing the examination a second time are dismissed from the doctoral program.
- f. The Committee for the Qualifying Examination may require the student who has been successful in the Ph. D. Qualifying Examination to take up to three additional courses even if the student has completed the normal course load.



